



Link to feedback form:
<http://shoutkey.com/peach>

Tusic Sprint 1 Review

Athmika, Emily, Hannah, Kristen,
and Magnolia



We will design and fabricate a **page turner for musicians** that is actuated with a **hands-free** method.



MVP

Required aspects:

- » Can turn at least one kind of sheet music reliably
 - » Is triggered by something without hands
 - » Constructed professionally (no wires, tape, cardboard showing)
 - » Has been tested by a musician for usefulness
- 

Learning Goals

EMILY

System
integration,
program
hands-free
inputs

HANNAH

CAD, rapid
prototyping,
mechanisms,
system
integration

KRISTEN

System
integration,
Open-source
programming,
Prototyping

ATHMIKA

Writing more
readable code

MAGNOLIA

Tidier circuits,
Electrical
troubleshooting



Stretch Goals

Mechanical

- » Handle loose leaf and music in binders
- » Flip forward and backwards
- » Should not interfere with the ability to read music

Hardware

- » Seamless integration with RasPi
- » Battery operated

Software

- » Different modes for “learning” when to turn
 - » Turning controlled by eye movement
- 



Demo

Deliverable 1: Prototype mechanical design

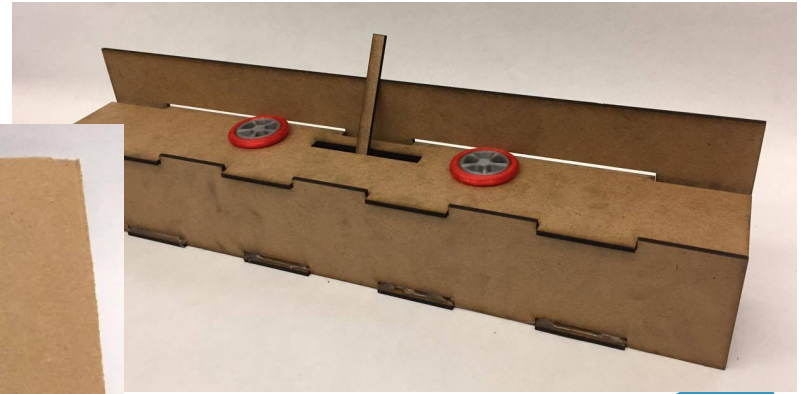
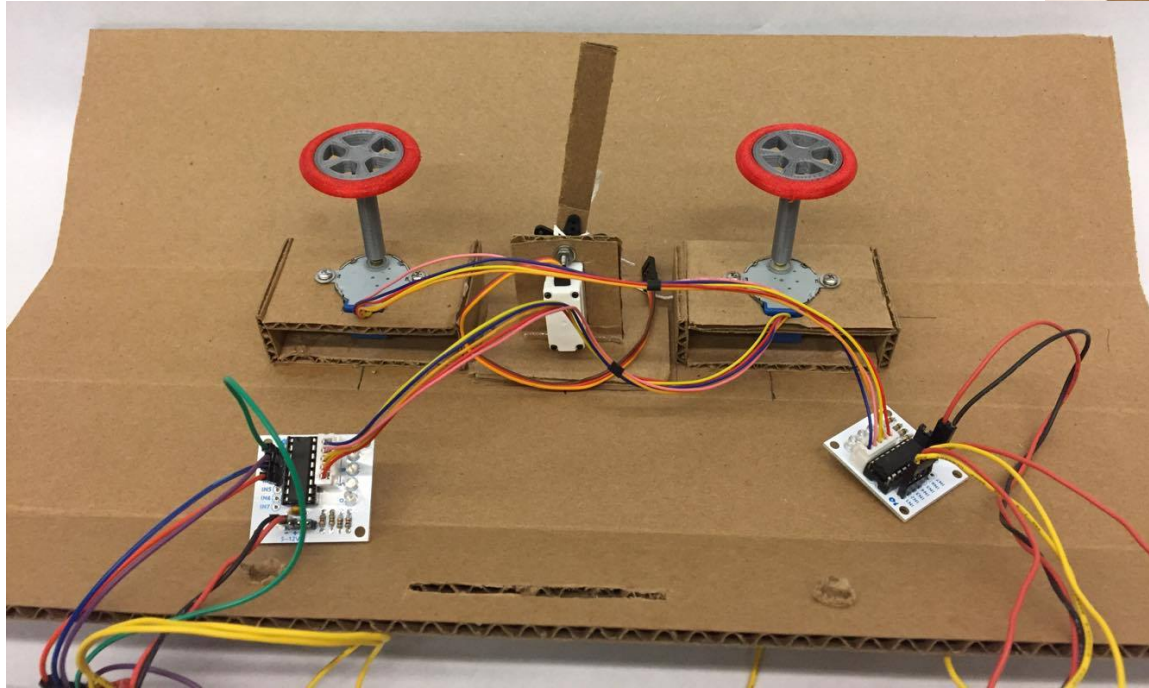

Deliverable 2: Button input to trigger system

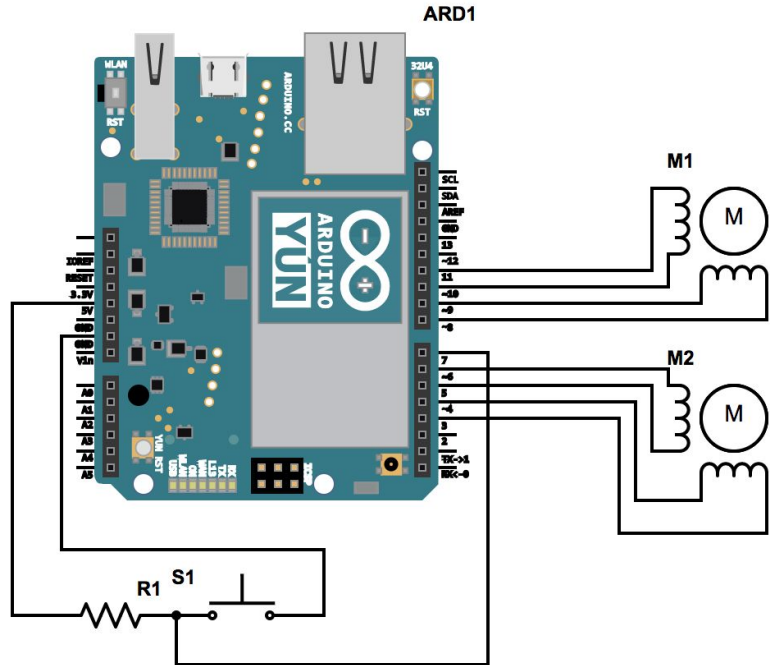

Deliverable 3: Integrated System

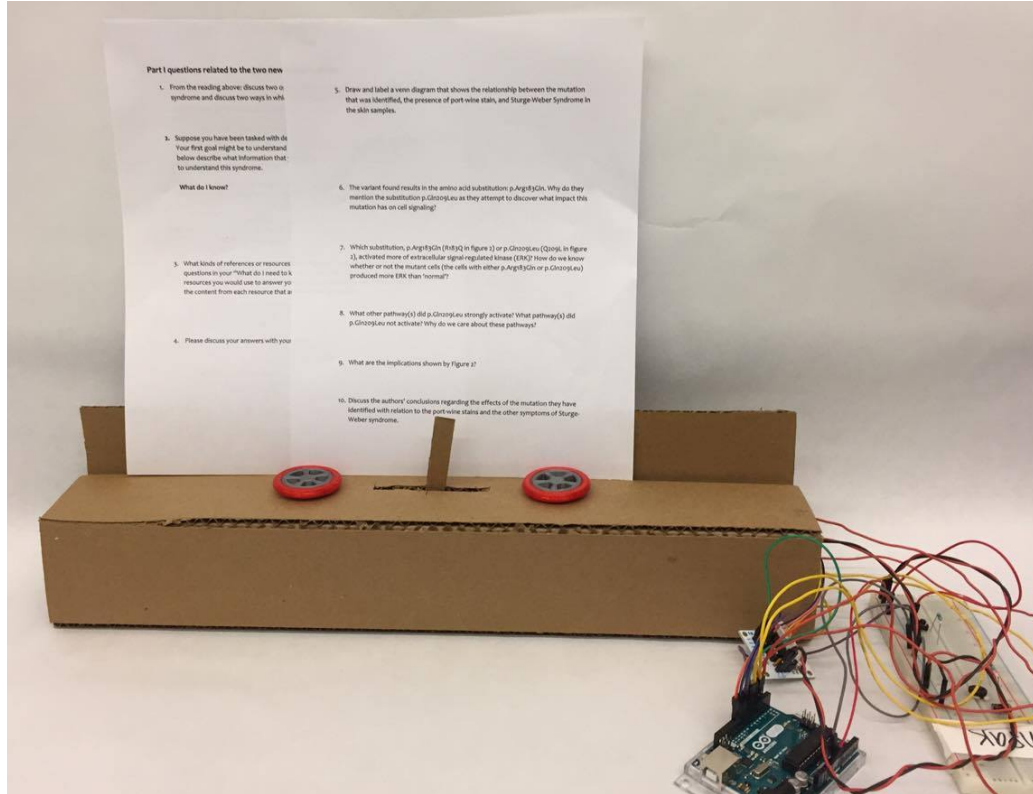

Deliverable 4: Eye-tracking software prototype

Both eyes

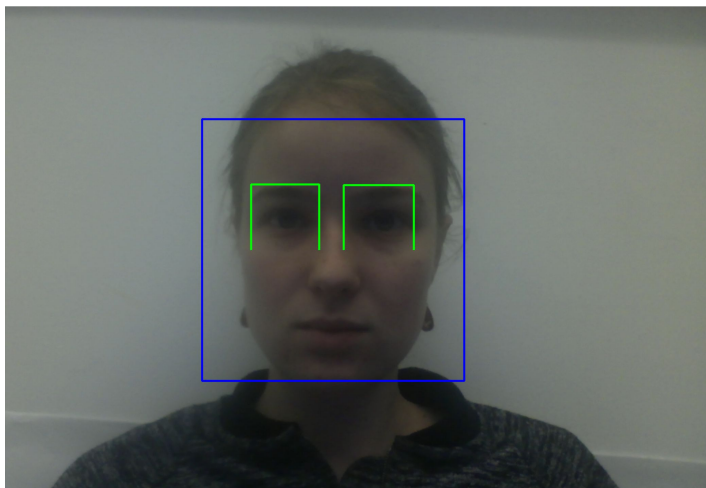

Wink

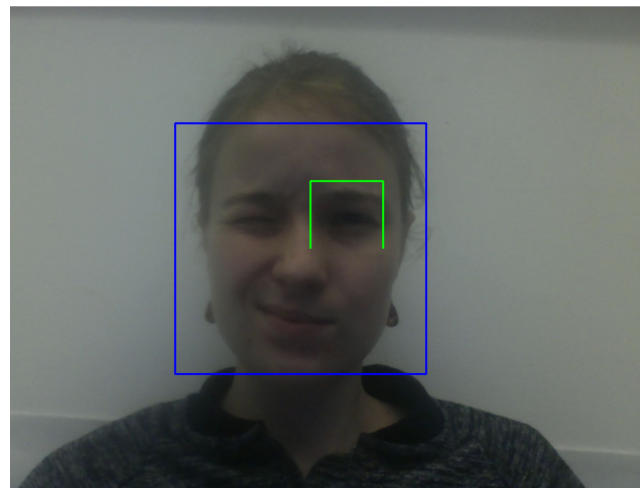

Deliverable 5: First draft of website

Blog

The Decision: A Page-Turner for Musicians

Posted on October 15, 2017

After our last group meeting, we had come to a bit of a deadlock. We couldn't agree on whether we wanted to work on a page-turner or a safety jacket for biking. Last night, however, we finally reached our decision. We will be creating a page-turner for musicians. Personally, I was originally leaning toward the safety jacket. The element that made me change my mind was identifying a clear user for our page-turner. When playing an instrument, both hands are usually occupied. This makes turning sheet music pages difficult and stressful. Additionally, sheet music is generally of a standard size and comes in specific forms (i.e. a stack of papers, a binder, or a paperback book). If this were a generic page turner, there would be many more variables, specifically, the size of books. We also believe that having a specific user in mind will help our design decisions as we move forward.

[Continue reading →](#)

[Leave a comment](#)
[Edit](#)

Day 0: Ideas, ideas, ideas!

Posted on October 13, 2017

Today marks the first day of our final Principles of Engineering project. Last night, I found that my team co (Kristen), Athmika, Emily, Hannah, and Maggie. We have three Software Engineers, one Mechanical Engineer, and one Physicist. This seems like quite a solid spread of skill-sets, and considering that I almost chose Electrical Engineering as my major, I feel confident that we will be able to accomplish electrical aspects of our project as well.

[Continue reading →](#)



RECENT POSTS

The Decision: A Page-Turner for Musicians

Day 0: Ideas, ideas, ideas!

RECENT COMMENTS

ARCHIVES

October 2017

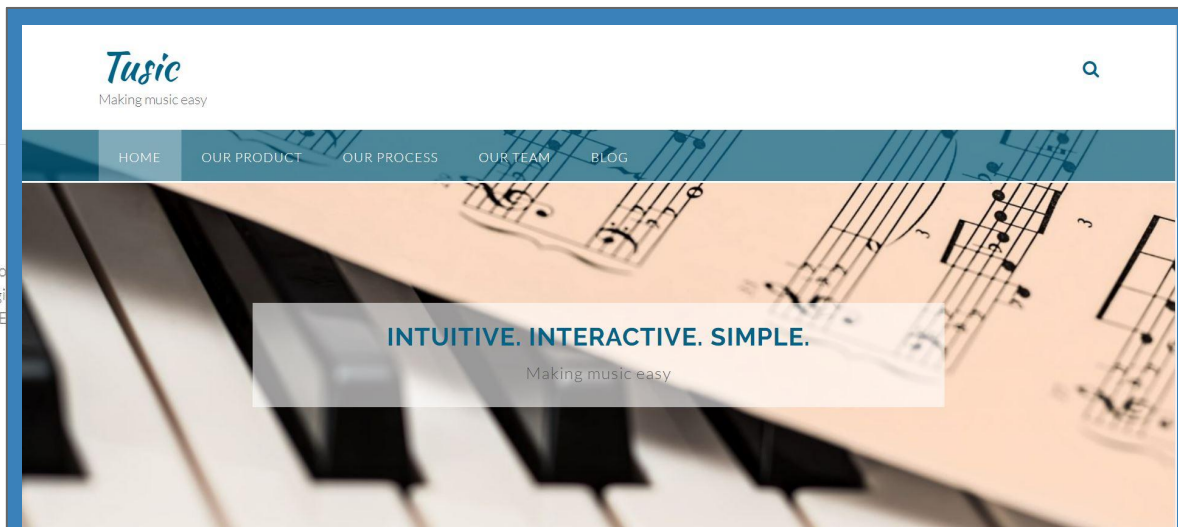



Current Challenges

Software

- » Communication between camera and system
- » Distance calibration

Mechanical

- » Getting motors to move simultaneously
 - » Methods/materials for moving paper
 - » Actuation to handle stacks
- 



Deliverables for next sprint

- » Integrate eye and motor control with Raspberry Pi
 - » Better mechanical prototype (no cardboard)
 - » Capability to turn several pages of music
- 