

ASL Fingerspelling Translator Glove

Jamal Haydar¹, Bayan Dalal², Shahed Hussainy³, Lina El Khansa⁴, Walid Fahs⁵

Faculty of Engineering, Islamic University of Lebanon
Khaldeh, Lebanon

Abstract

In this paper, we describe an automatic sign language to text translation system. This system consists of a glove that can be worn by a deaf to facilitate its conversation in real-time with hearing persons. The system translates the signs to the corresponding letters, using Bluetooth communication, to a PC that displays the result letters. The recognition of the sign is accomplished using five flex sensors and a 3-axis accelerometer; the signals are converted to digital data, which is compared with a lookup table to get the resulted letter.

This system is suspected to help deaf people to communicate with other persons without the need of a human translator.

Keywords: American Sign Language, Fingerspelling, Bluetooth communication, Flex sensors, Accelerometer, Deaf people.

1. Introduction

As the third or fourth most widely used language in the United States [1], American Sign Language (ASL) is the primary communication means used by members of the North American deaf community. There is linguistic, psycholin-guistic, and neurological evidence in favor of ASL being a fully developed natural language [2]. It is not a derivative of English it is a complete language with its own unique grammar [3, 4, 5].

While the last ten years have seen an ever increasing development of machine translation systems for translating between major spoken natural languages, translation to and from ASL is virtually ignored by the machine translation community. Yet, ASL translation systems are very important to the deaf.

The communication between deaf and hearing persons poses a much stronger problem than the communication between blind and seeing people. While the latter can talk freely by means of a common spoken language in which both are equally proficient, the deaf have their own, manual-visual language.

ASL is produced in a modality (or channel) that is greatly different from English: ASL is a signed language; it cannot be spoken; and there is currently no accepted form of written ASL [5]. The earlier commonly-used means of referring to signs in writing is *glosses* notation, whereby signs are represented in their natural order by upper case words taken from their nearest spoken counterparts [6]. A major drawback of this representation is that it does not show what the translated signs look like [7, 8]. More recent methods use relatively iconic, picture-like symbols to represent the positions and movements of the hands, as well as the facial expressions, but failing to incorporate spatial elements into the representation, this kind of writing system can still cause confusion in complex signs.

The main purpose of this paper is to present a system that can translate real time fingerspelling of the American Sign Language into text. It may improve communication of people with hearing disability. Our system is integrated into a glove that could be put in the deaf hand. It works by sensing the hand movements of the deaf when making signs from sign language alphabet, and then it recognizes data and transmits it wirelessly to a PC in order to display the correspondent letter. We built a prototype of the sign language translator using a fabric glove with five Flex sensors to detect the bending of the fingers, 3-axis accelerometer on the back of the palm to measure dynamic and static gestures, a small circuit board containing a programmable microcontroller to detect hand postures of American Sign Language.

The device only translates the alphabet, but we can customize a hand movement to mean a particular word.

The remainder of the paper is constructed as follows. Section 2 introduces the Fingerspelling used in sign languages. The overall system description is presented in section 3. Section 4 details the used materials such as the flex sensors, the accelerometer, the microcontroller, the Bluetooth module and the receiver part which contains the

display software. The system functionality with the letter recognition process and the lookup tables are described in section 5. Finally, we conclude the paper in section 6 and outline the future avenues for our work.

2. Fingerspelling

In the American Sign Language (ASL) manual alphabet, fingerspelling is used primarily for spelling out names or English terms which do not have established signs [9]. Most of the letters are shown as the viewer would see them, but some (C, D, G, H, K, P, Q, and to a lesser extent F, O, X) are shown from the side for clarity (Fig. 1). However, it is also used for emphasis for clarity, and for instruction.

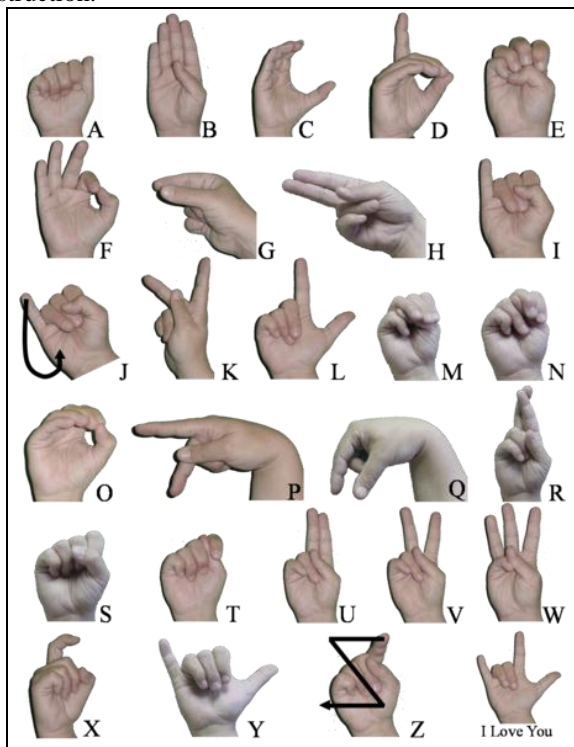

Fig. 1: The ASL Manual Alphabet.

3. System Description

The deaf wears the glove and makes the letter gesture according to the American Sign Language dictionary. The Flex sensors and the accelerometer that were placed on the glove will deliver a voltage signal that specifies the concerned letter. The conversion from analog to digital will be done in the microcontroller and the selection of the letter will be done too by developed software. Then, the signal will be transmitted to a Bluetooth module that will

transmit it to the computer, which receives data via a Bluetooth receiver, decodes and displays the letters on the screen using a Visual Basic interface.

The designed glove contains the following components: the batteries, five Flex sensors, an accelerometer, a main electronic board with its push button, and a Bluetooth serial module with its adapter board.

The main electronic board contains a microcontroller that handles the program used to detect the analog voltage levels captured from the sensors, converts them to digital using the ADC of the microcontroller, makes the recognition of the letter signed and sent data to the Bluetooth module. The recognition program is written in basic language using Proton-IDE software. The electronic board itself is designed in two layers using Express PCB software. The block diagram of the ASL Fingerspelling translator system is shown in Fig.2.

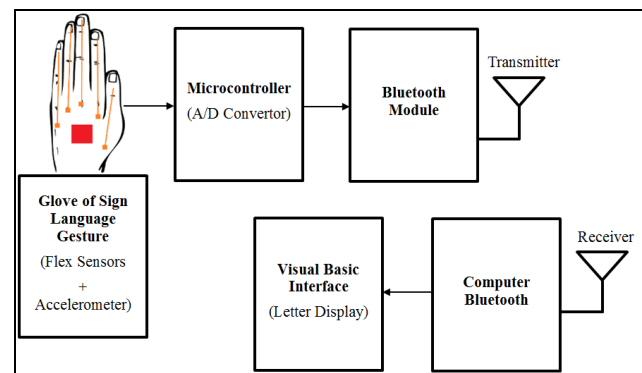

Fig. 2: Sign Language Translator Glove Block Diagram.

4. Used Materials

To reach our goal in this project, we used the following main materials: Flex sensors and Accelerometer, Amplifiers, Microcontroller, Bluetooth Module Board, Battery, and Voltage Regulators for the electronic circuit on the glove, whereas the result will be visualized on the receiver Computer.

4.1 Flex sensors

The Flex sensors (Fig. 3) are sensors that changes in resistance depending on the amount of bend on the sensor. They convert the change in bend to electrical resistance; the more the bend, the more the resistance value increase. They are usually in the form of a thin strip from 1'' to 5'' long that vary in resistance; they could be made in a unidirectional or bidirectional form.

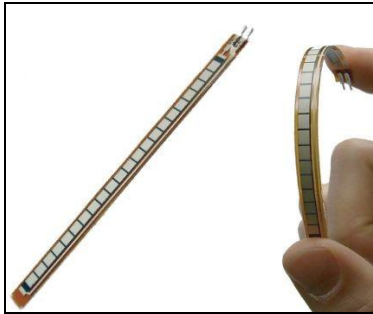

Fig. 3: 4.5" Unidirectional Flex Sensor.

As Flex sensors are analog resistors, they work as variable analog voltage dividers: when the substrate is bent, the sensor produces a resistance output relative to the bend radius (Fig. 4) [10].

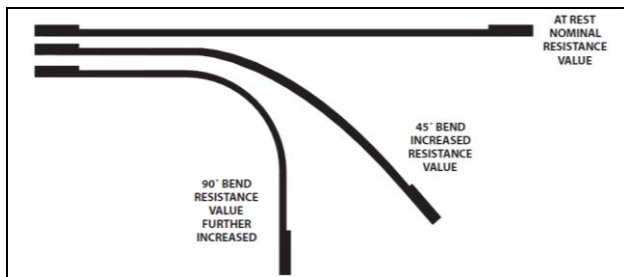

Fig. 4: Flex Sensor Offers Variable Resistance Readings.

The impedance buffer in the Basic Flex Sensor Circuit is a single sided Operational Amplifier, used with these sensors because the low bias current of the Op-Amp reduces error due to source impedance of the flex sensor as voltage divider (Fig. 5). Suggested Op-Amps are the LM358 or LM324.

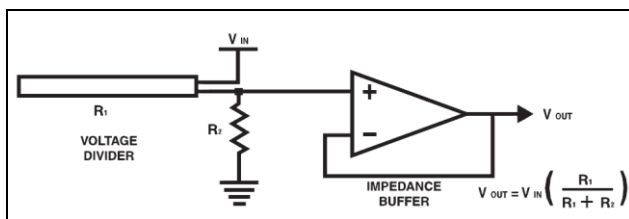

Fig. 5: Basic Flex Sensor Circuit.

4.2 Amplifier

After detecting the voltage signals of the Flex sensors, it passes through an amplifier to differentiate and amplify the different signals detected. We have used 2 amplifiers ICs of model LM324 [11]. The first amplifier used for the outputs of 4 Flex sensors on thumb, index, middle, and

ring fingers while the second one used for the pinky finger Flex sensor output.

The circuit of this Op-Amp consists of four independent, high gains, internally frequency compensated operational amplifiers. They operate from a single power supply over a wide range of voltages. Operation from split power supplies is also possible and the low power supply current drain is independent of the magnitude of the power supply voltage.

4.3 Accelerometer

To detect the letters 'J' and 'Z', which require movement in addition to hand position, we add an accelerometer to detect the movement of the glove/hand. The accelerometer ADXL335 is a small, thin, low power, complete 3-axis accelerometer with signal conditioned voltage outputs. It contains a polysilicon surface-micro machined sensor and signal conditioning circuitry to implement open-loop acceleration measurement architecture. The output signals are analog voltages that are proportional to acceleration. The accelerometer can measure the static acceleration of gravity in tilt-sensing applications as well as dynamic acceleration resulting from motion, shock, or vibration.

Fig. 6 shows the functional block diagram of the accelerometer ADXL335. The sensor is a polysilicon surface-micro machined structure built on top of a silicon wafer. Polysilicon springs suspend the structure over the surface of the wafer and provide a resistance against acceleration forces. Deflection of the structure is measured using a differential capacitor that consists of independent fixed plates and plates attached to the moving mass. The fixed plates are driven by 180° out-of-phase square waves. Acceleration deflects the moving mass and unbalances the differential capacitor resulting in a sensor output whose amplitude is proportional to acceleration. Phase-sensitive demodulation techniques are then used to determine the magnitude and direction of the acceleration [12]. The demodulator output is amplified and brought off-chip through a 32kΩ resistor.

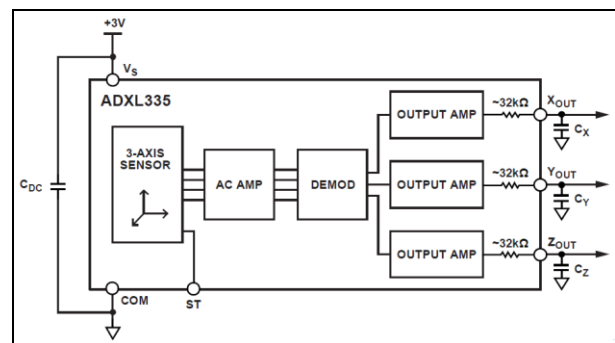

Fig. 6: Functional Block Diagram of Accelerometer ADXL335.

The 3-Axis sensor block (Fig. 6) is a mechanical sensor that uses a single structure for sensing the X, Y, and Z axes. As a result, the three axes' sense directions are highly orthogonal and have little cross-axis sensitivity. Mechanical misalignment of the sensor die to the package is the chief source of cross-axis sensitivity. Mechanical misalignment can be calibrated out at the system level.

The bandwidth of the accelerometer is selected using the C_X , C_Y , and C_Z capacitors at the X_{OUT} , Y_{OUT} , and Z_{OUT} pins. Bandwidths can be selected to suit the application, with a range of 0.5 Hz to 1600 Hz for the X-axis and Y-axis, and a range of 0.5 Hz to 550 Hz for the Z-axis.

To meet our project requirements, and after many experiments, we have used a value of 0.1 μF for C_X , C_Y , and C_Z capacitors.

4.4 PIC Microcontroller

PIC16F874A is one of the most popular microcontrollers which are commonly used. This microcontroller is based on RISC architecture and has 40 pins with 33 input/output ports. It is possible to process data with PIC16F877A microcontroller of which oscillator frequency can reach up to 20 MHz [13]. There are two main reasons to choose PIC16F877A in our project: First one, that it had eight analog inputs (from AN0 to AN7) needed to process the signals captured from the eight sensors. The last one is that it contains a TX serial module needed to transmit data to the Bluetooth module.

The PIC microcontroller is used as the core of the system, it captures analog signals from sensors, converts them to digital through the integrated ADC module and do the recognition process by using a lookup table. When the letter is recognized, a corresponding digital value will be sent via the TX pin (integrated serial module) to the Bluetooth serial module board.

4.5 Bluetooth Module

The EasyBT Board [14] features the Bluetooth wireless protocol that utilizes a short-range communication technology facilitating data transmission over short distances from fixed and/or mobile devices, thus creating wireless personal area networks (PANs). The intent behind the development of Bluetooth was to create a single digital wireless protocol capable of connecting multiple devices and overcoming problems arising from synchronization of these devices.

The preconfigured Bluetooth module sent data, received serially from the microcontroller, to a receiver module connected to a PC.

4.6 Voltage Regulators

Flex sensors, amplifiers, and microcontroller need a 5V power source, therefore we have used voltage regulator (7805) to convert any voltage greater than or equal 7V into 5V [15].

The Bluetooth module board and the accelerometer need a 3.3V power source. For that purpose we have used voltage regulator (LM3940) that convert the 5V into 3.3V [16].

The best choice for a power supply that provides us with more than 7V and work properly for a long time where at the same time can be placed on the glove and handled by the human hand easily; was a 9V Battery.

4.7 Receiver Computer and Display Software

A Computer with Bluetooth device will be used for receiving the data from the Bluetooth serial module board on the glove and display it on the Computer screen.

To decode the received data, convert it to a corresponding letter and display it on the screen, we developed a software using Visual basic to be an interface for our project. This software has a simple interface to be user friendly and has the capabilities to display one translated letter or a sequence of adjacent letters, record them for a latter usage, detects silent periods between sequences of letters and adds spaces to separate words. It displays an error message if an error signal has been sensed such as no matching between the hand gesture of the user and the look-up table, or when the button is pressed before making an exact sign by the hand.

5. System Functionality

When power is ON, the position and orientation of hand is obtained from the data glove that consists of a total of eight sensors: five Flex sensors on fingers (Thumb, index, middle, ring, and pinky) and one accelerometer of three outputs (X, Y, and Z positions). Tilting of the palm can be captured by the accelerometer where Flex sensors can measure the bend of the five fingers when making a sign.

When the user performs a gesture/letter and press a button, eight signals coming from the eight sensors are amplified via a dedicated amplification circuit to each signal, and then captured by the microcontroller which converted the analog signals to digital values through its 8-channel ADC (on Port A). These values are formatted into a simple state matrix: five values for the Flex sensors, and one for each axis of the accelerometer. When the push button is pressed, the microcontroller takes the value and makes the A/D conversion to compute the most likely gesture that has been performed based on the current state of the hand. The recognition process is done by using a lookup table of all possible states of the eight sensors; a record in this table

represents a combination of the values of the eight sensors to get a specific letter. After recognition, the microcontroller sends data through the TX pin to the Bluetooth module. If there is no letter matches the current state of the hand, an error message appears on the screen. Fig. 7 illustrates the flowchart of the capturing and recognition process.

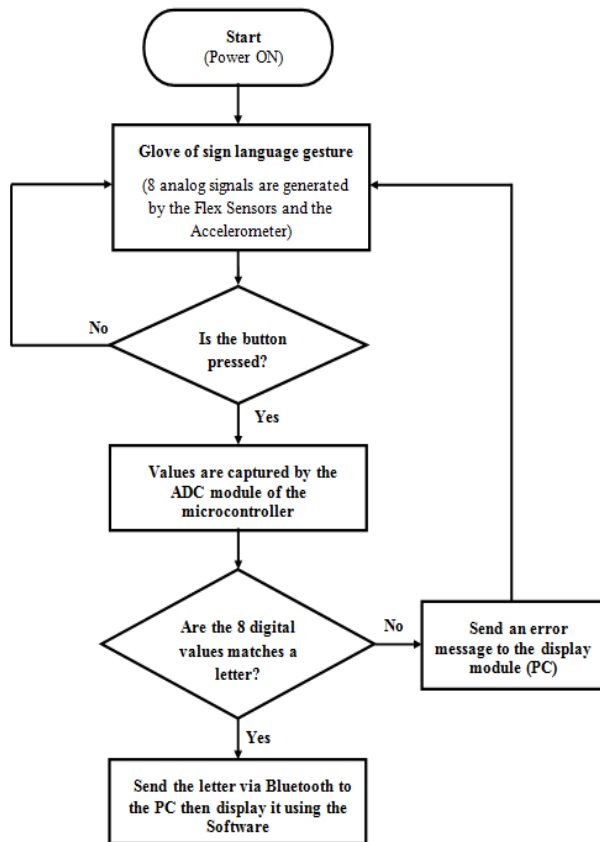

Fig. 7: Flowchart of the capturing and recognition process.

We obtained experimentally in our laboratory, for each letter the corresponding signals, from the Flex sensors and the accelerometer. These values are determined by the analog output voltage given from each sensor. The analog outputs values for fingers and accelerometer axes are given in Table 1.

These values are then converted to their corresponding digital level according to Eq. (1).

$$Digital\ Level = (Analog\ value \times 255) / 5 \quad (1)$$

As a result, each letter in the ASL will have a specific digital level for the five fingers and the three axis of the accelerometer. Each level is represented by a value between 0 and 255, an interval of ± 3 levels should be taken into consideration in case the user could not keep his hand steady.

The corresponding digital levels are given in Table 2; which is used as a lookup table.

The program will search in the look-up table to find the related letter and when there is no matching with any letter, an error message will be displayed.

Table 1: Analog Outputs for Fingers and Accelerometer Axes.

Letter	Thumb	Index	Middle	Ring	Pinky	X-axis	Y-axis	Z-axis
A	3.77	3.07	3.20	3.54	3.20	1.97	1.64	1.61
B	3.73	3.54	3.68	3.75	3.75	1.96	1.63	1.58
C	3.75	3.36	3.4	3.69	3.64	1.97	1.61	1.62
D	3.77	3.54	3.41	3.66	3.58	1.97	1.61	1.66
E	3.6	3.12	3.25	3.55	3.37	1.96	1.65	1.61
F	3.7	3.13	3.68	3.75	3.75	1.96	1.66	1.57
G	3.77	3.48	3.2	3.54	3.28	1.9	1.8	1.78
H	3.76	3.54	3.68	3.69	3.47	1.82	1.89	1.7
I	3.68	3.07	3.23	3.57	3.75	1.97	1.63	1.62
J	3.68	3.08	3.23	3.57	3.75	1.9	1.79	1.64
K	3.77	3.54	3.61	3.68	3.35	1.95	1.71	1.6
L	3.77	3.54	3.28	3.57	3.36	1.97	1.61	1.61
M	3.66	3.19	3.33	3.53	3.39	1.97	1.66	1.57
N	3.72	3.18	3.39	3.72	3.24	1.96	1.67	1.57
O	3.71	3.27	3.38	3.6	3.54	1.97	1.62	1.58
P	3.77	3.54	3.59	3.66	3.44	1.8	1.66	1.89
Q	3.77	3.49	3.24	3.6	3.5	1.68	1.61	1.95
R	3.77	3.49	3.61	3.56	3.38	1.96	1.61	1.58
S	3.68	3.04	3.2	3.45	3.35	1.97	1.63	1.61
T	3.72	3.2	3.38	3.63	3.35	1.97	1.65	1.6
U	3.77	3.54	3.66	3.67	3.43	1.97	1.65	1.59
V	3.77	3.54	3.65	3.6	3.45	1.97	1.65	1.58
W	3.72	3.54	3.68	3.75	3.4	1.97	1.65	1.58
X	3.68	3.38	3.23	3.39	3.38	1.97	1.65	1.64
Y	3.77	3.18	3.31	3.46	3.75	1.95	1.74	1.65
Z	3.77	3.51	3.23	3.54	3.35	1.96	1.68	1.65

Table 2: Look-Up Table of Digital Levels for Fingers and Accelerometer Axes Outputs.

Letter	Thumb	Index	Middle	Ring	Pinky	X-axis	Y-axis	Z-axis
A	192	157	165	181	172	100	84	82
B	190	181	188	191	191	100	83	81
C	191	171	173	188	191	100	82	83
D	192	181	174	187	186	100	82	85
E	184	159	166	181	169	100	84	82
F	189	160	188	191	191	100	85	80
G	192	177	163	181	167	97	92	91
H	192	181	188	188	177	93	96	87
I	188	157	165	182	191	100	83	83
J	188	157	165	182	191	97	91	84
K	192	181	184	188	167	99	87	82
L	192	181	167	182	171	100	82	82
M	187	163	170	180	173	100	85	80
N	190	162	173	190	168	100	85	80
O	189	167	172	184	181	100	83	81
P	192	181	183	187	175	92	85	96
Q	192	178	165	184	179	87	82	99
R	192	178	184	182	172	100	82	81
S	188	155	163	176	171	100	83	82
T	190	163	172	185	171	100	84	82
U	192	181	187	187	175	100	84	81
V	192	181	186	184	176	100	84	81
W	190	181	188	191	173	100	84	81
X	188	172	165	173	172	100	84	84
Y	192	162	169	176	191	99	89	84
Z	192	179	165	181	171	100	86	84

Fig. 8 shows the flex sensors integrated in a glove, and the person who wears it makes the sign correspondent to the letter 'A', the result is displayed directly on the PC screen.

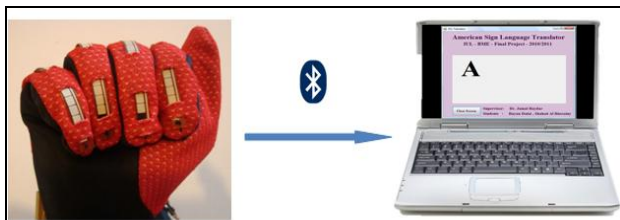

Fig. 8: The glove with the flex sensors make the sign of the letter 'A'.

5. Conclusion and Future Works

Deaf people rely on sign language interpreters for communication. However, they cannot depend on interpreters in everyday life mainly due to high costs and difficulty in finding and scheduling qualified interpreters. This system will help them in improving their quality of life significantly.

The goal of this project is to design a useful and fully functional real-world product that efficiently translates the movement of the fingers for the fingerspelling of American Sign Language (ASL). Our motivation is to help deaf people communicate more easily. The ASL Fingerspelling Translator Glove (ASLFTG) also teaches people to learn the ASL and it uses a glove to recognize the hand positions and outputs the ASL onto a display. The glove detects the position of each finger by monitoring the bending of the Flex sensors. ASL is a visual language based on hand gestures, it has been well developed by the deaf community over the past centuries and it is the third most used language in the United States today. Our project is very safe: there is no contact made directly to the person that uses the glove. The device operates at a very low voltage and is very unlikely to hurt someone. The nature of the device is one such that it is unlikely that the public or the environment could be endangered in any way.

Some improvements on this project include implementing a free mode where the system will recognize any letter being signed, adding word vocabulary (need to use another glove for the other hand) or detecting the letters on a mobile device that would have been useful for creating a more user-friendly display.

References

- [1] M. Sternberg, "The American Sign Language Dictionary", Multicom, 1996.
- [2] L. Messing, and R. Campbell, "Gesture, Speech and Sign", Oxford University Press, 1999.
- [3] V. Fromkin, "Sign language: Evidence for language universals and the linguistic capacity of the human brain", Sign Language Studies, 59, 115-127, 1988.
- [4] C. Valli, and C. Lucas, "Linguistics of ASL: An Introduction", Gallaudet University Press, 1995.
- [5] S. Wilcox, and P. Wilcox, "Learning to See", Gallaudet University Press, Washington, DC, 1996.
- [6] J. Bungeroth, and H. Ney, "Statistical Sign Language Translation", Computer Science Department, RWTH Aachen University, Germany.
- [7] C. A. Padden, "Folk Explanation in Language Survival in Deaf World: A Historical Reader and Primary Sourcebook", Lois Bragg, Ed. New York: New York University Press. P:107-108, 2001.
- [8] B. Farnell, "Do You See What I Mean? Plains Indian Sign Talk and the Embodiment of Action", University of Nebraska Press, Lincoln and London, P: 2, 1995.

- [9] E. Costello, "Random House Webster's American Sign Language Dictionary", New York: Random House Reference, 2008.
- [10] "Flex Sensor Data Sheet", ISO 9001:2000 Certified, SpectrSymbol, Salt Lake City, Utah.
- [11] LM324 Data Sheet, "Low Power Quad Operational Amplifiers", STMicroelectronics, Italy, 2001.
- [12] ADXL335 Data Sheet, "Small and Low Power 3-Axis ± 3 g Accelerometer", Analog Devices Inc., USA, 2009.
- [13] PIC16F87XA Data Sheet, "28/40/44-Pin Enhanced Flash Microcontrollers", Microchip Technology Inc., USA, 2003.
- [14] EasyBT- RBT-001 Data Sheet, "Bluetooth Serial Module", RoboTech srl, Italy.
- [15] KA7805 Data Sheet, "3-Terminal 1A Positive Voltage Regulator", Fairchild Semiconductor Corporation, 2001.
- [16] LM3940 Data Sheet, "1A Low Dropout Regulator for 5V to 3.3V Conversion", National Semiconductor Corporation, 2007.